

SUMMARY

- C- 4 Bracket for focusing cloth
- C- 6 Normal bellows
- C- 7 Lensboard 00-shutter
- C- 10 Monorail 44 cm/17"
- C- 11 Spring back
- C- 15 Normal bellows
- C- 16 Monorail 54 cm/21"
- C- 17 Wide angle bellows leather
- C- 18 Wide angle bellows leather
- C- 19 Bellows support
- C- 20 Aluminium case SC/SCN-2
- C- 21 Aluminium case SC-3 + Legend 2
- C- 22 Carrying case for SCN/SC-2
- C- 30 Groundglass frame not ruled
- C- 31 Groundglass frame ruled
- C- 34 Bracket for focusing cloth
- C- 37 Monorail 75 cm/30"
- C- 39 Aluminium case Legend-4
- C- 40 Sliding back with 2x 4x5" ground glass back
- C- 42 Recessed lensboard 00-shutter
- C- 43 Groundglass ruled
- C- 44 Groundglass ruled
- C- 45 Monorail 100 cm/40"
- C- 46 Adapter for Hasselblad body
- C- 50 Safety lock
- C- 51 Cable release
- C- 54 Groundglass ruled
- C- 56 Spirit level, single
- C- 64 Monorail 30 cm/12"
- C- 93 Lensboard adapting Linhof
- C- 103 Lensboard adapting Sinar
- C- 141 Supersharp focusing screen
- C- 142 Supersharp focusing screen
- C- 143 Supersharp focusing screen
- C- 144 Multi purpose standard
- C- 158 Fresnel lens 4x5"
- C- 161 Fresnel lens 5x7"
- C- 162 Fresnel lens 8x10"
- C- 166 Groundglass not ruled
- C- 168 International back
- C- 169 Focusing magnifier 4x
- C- 170 Focusing magnifier 6x
- C- 176 Fidelity cutfilm holder 2 1/4"x3 1/4"
- C- 177 Fidelity cutfilm holder 9x12 cm
- C- 178 Fidelity cutfilm holder 4x5"
- C- 179 Fidelity cutfilm holder 13x18 cm
- C- 180 Fidelity cutfilm holder 5x7"
- C- 181 Fidelity cutfilm holder 18x24 cm
- C- 182 Fidelity cutfilm holder 8x10"

- C- 326 Wide angle bag-bellows synthetic
- C- 333 Spring back
- C- 336 Normal bellows
- C- 340 Compendium Basic
- C- 341 Compendium Deluxe with filterholder
- C- 378 Monorail connector/double tripod mount
- C- 463 Lensboard adapting 23 SF lensboards
- C- 468 Revolving international back 4x5"

- CBH- 2 Cambo Ball Head small
- CBH- 3 Cambo Ball Head medium
- CBH- 5 Cambo Ball Head large
- CBH- 5QR Cambo ball Head large with quick release

- LM- 9 Tripod mounting
- LM- 10 Support base
- LM- 17 Monorail 17 cm/6 1/2"
- LM- 19 Bellows support
- LM- 25 Monorail extension 25 cm/10"
- LM- 26 Monorail 25 cm/10"
- LM- 42 Monorail extension 42 cm/16 1/2"
- LM- 43 Monorail 42 cm/16 1/2"
- LM- 65 Monorail extension 65 cm/25 1/2"
- LM- 66 Monorail 65 cm/25 1/2"
- LM- 69 Extendible Monorail
- L- 84 2 Extenders for legend columns
- LM- 99 Double tripod mounting
- LM- 144 Multi purpose standard
- L- 135 Rear standard 8x10" Legend
- LP- 135 Rear standard 8x10" Legend plus
- M- 143 Groundglass ruled for Master plus
- M- 168 International back 4x5"
- M- 20 Carrying case Master plus
- M- 21 Carrying case accessories
- L- 23 Carrying case Legend 2/Legend 2 plus

- SF- 12 Front standard 45 SF
- SF- 13 Rear standard 45 SF
- SF- 20 Carrying case 45 SF
- SF- 57 Adapter for Hasselblad body
- SF- 62 Normal bellows
- SF- 73 Bracket for focusing cloth
- SF- 74 Groundglass ruled
- SF- 76 Bellows 2 1/4"x3 1/4" - 4x5"
- SF- 140 Supersharp focusing screen
- SF- 159 Fresnel lens 2 1/4"x3 1/4"
- SF- 210 Rollfilm adapter back
- SF- 211 Horseman rollfilm holder 6x9 cm
- SF- 212 Horseman rollfilm holder 6x7 cm
- SF- 250 Filmholder for Polaroid
- SF- 320 In line viewing hood
- SF- 322 Wide angle bag-bellows synthetic
- SF- 323 Wide angle bag-bellows synthetic
- SF- 461 Conversion kit 23SF to 4x5"
- SF- 462 Conversion kit 45SF to 23SF
- SF- 630 Lensboard 0-shutter
- SF- 631 Lensboard 1-shutter

- T- 11 Metal groundglass mask for C-214
- T- 12 Metal groundglass mask for C-213
- T- 14 Metal groundglass mask for C-220
- T- 20 Reflex viewing hood
- T- 21 In-line viewing hood
- T- 51 Cable release

- UL- 9 Tripod mounting block Ultima
- UL- 15 Rail extension 15 cm/6"
- UL- 30 Monorail 30 cm/12"
- UL- 318 Special bellows for Ultima D

- CSL- 23 Sliding back basic for 2x3 camera *
- CSL- 58 Sliding back basic for 4x5 camera *
- SSL- 59 Sliding back basic for Sinar camera *
- CMSL-245 2-step sliding back for 4x5 camera *
- CMSL-345 3-step sliding back for 4x5 camera *
- SMSL-245 2-step sliding back for Sinar camera *
- SMSL-345 3-step sliding back for Sinar camera *

- SL- 80 Hasselblad adapter plate
- SL- 82 Mamiya RZ adapter plate
- SL- 83 Mamiya 645 adapter plate
- SL- 84 Mamiya RB adapter plate
- SL- 85 Contax 645 adapter plate
- SL- 86 Bronica SQ adapter plate
- SL- 87 Bronica Etrsi adapter plate
- SL- 90 Mask for 24x36 mm format
- SL- 91 Mask for 31x31 mm format
- SL- 92 Mask for 37x37 mm format
- SL- 93 Mask for 2-step format
- SL- 94 Mask for 3-step format

- DP- 23 Direct adapting plate for 2x3 Cambo *
- DP- 45 Direct adapting plate for 4x5 Cambo *
- DP- SI Direct adapting plate for 4x5 Sinar *

* a choice of SL-80 upto SL-87 needs to be added

CAMBOsupplies a number of adapting possibilities for digital camera backs. Actual information can be obtained on request.

4x5" SF Ultima Legend Master ACCESSORIES

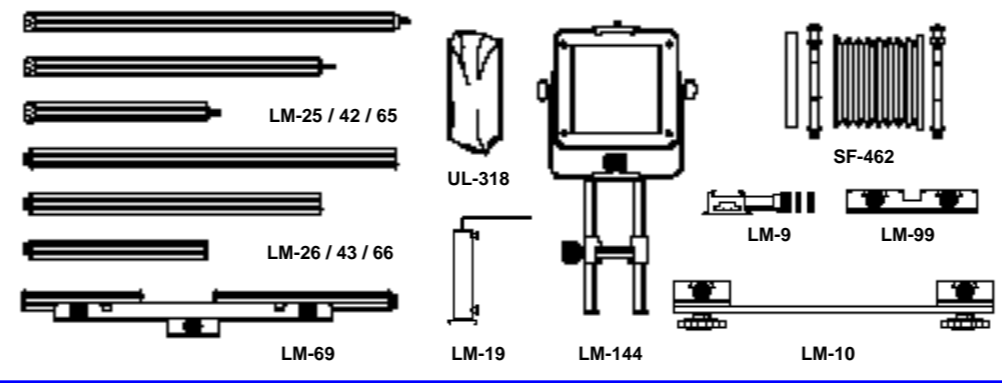

General 4x5" ACCESSORIES

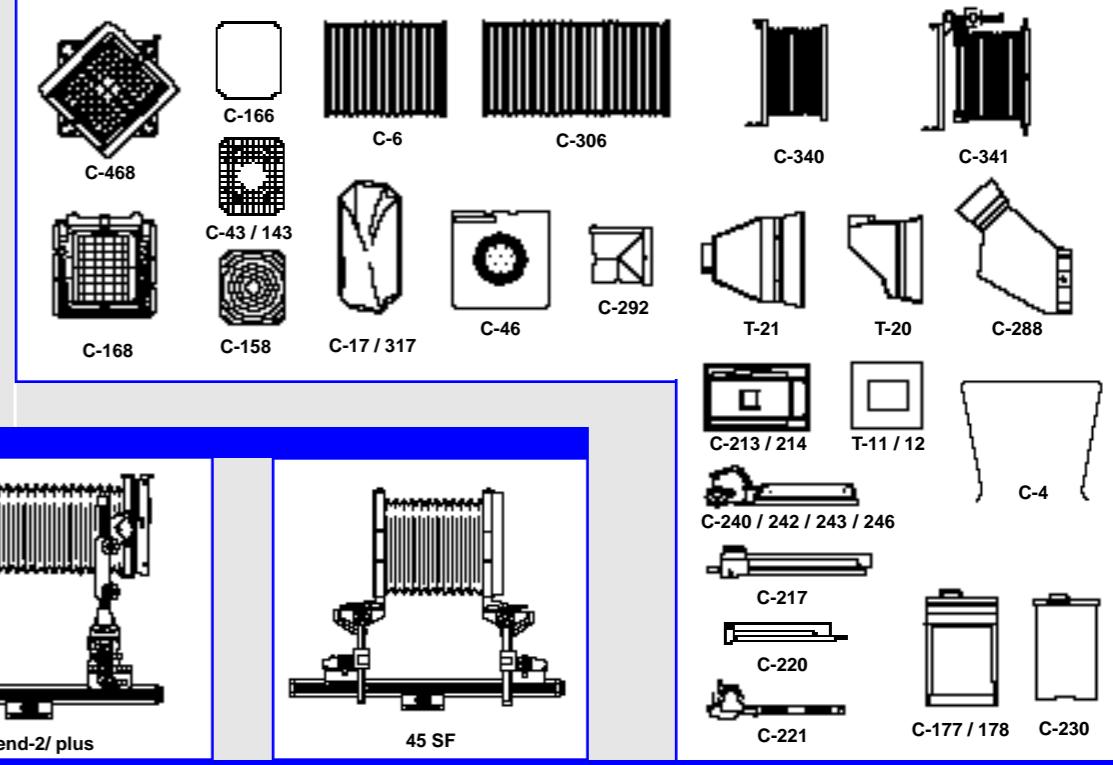

6x9 ACCESSORIES

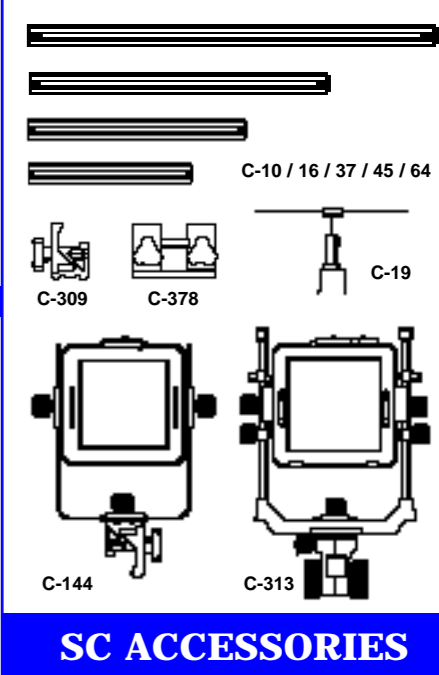
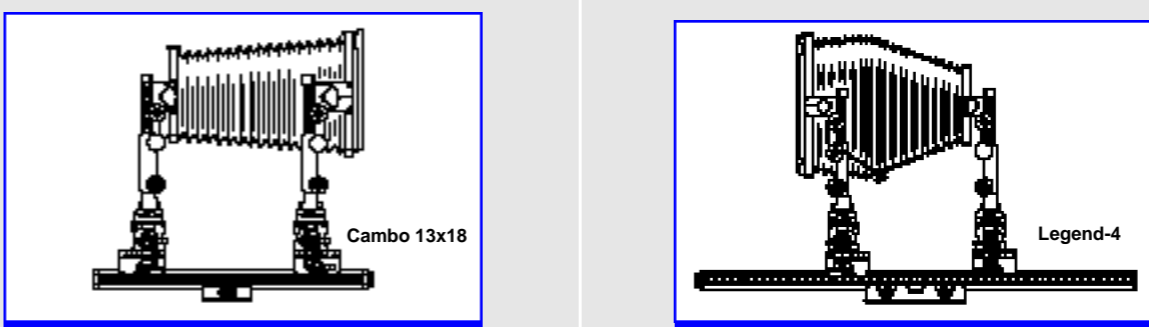
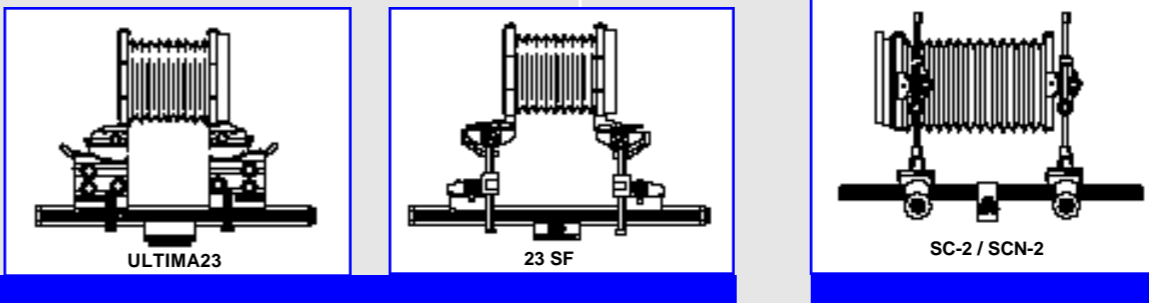
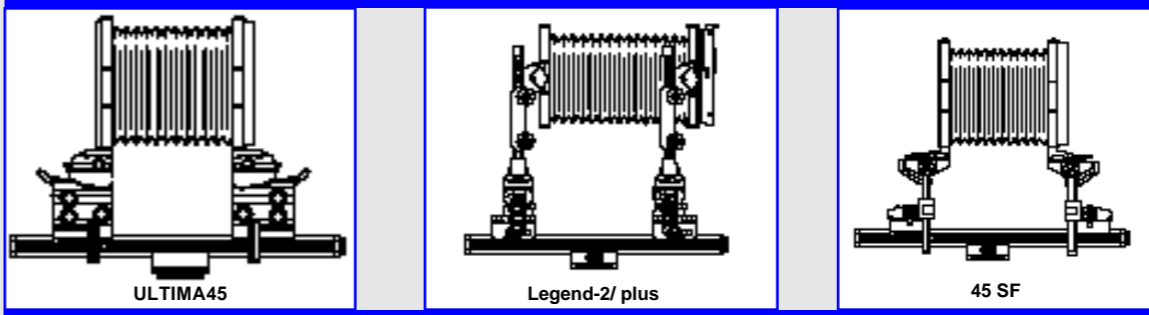
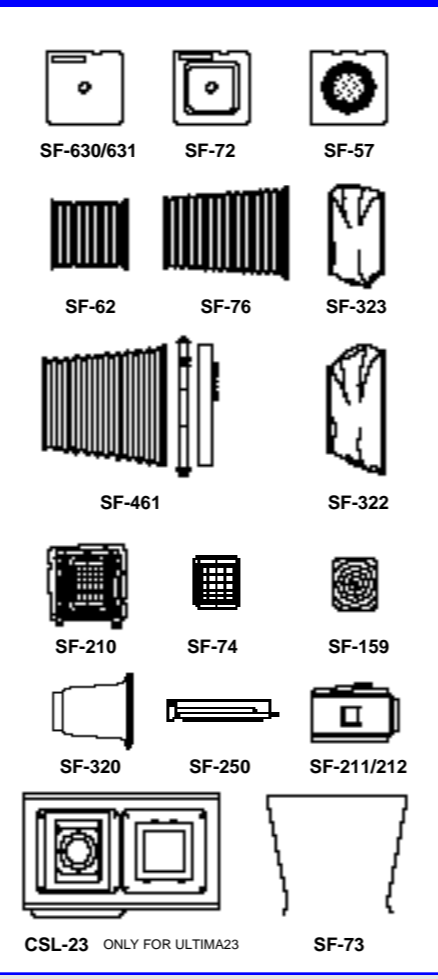

SC ACCESSORIES

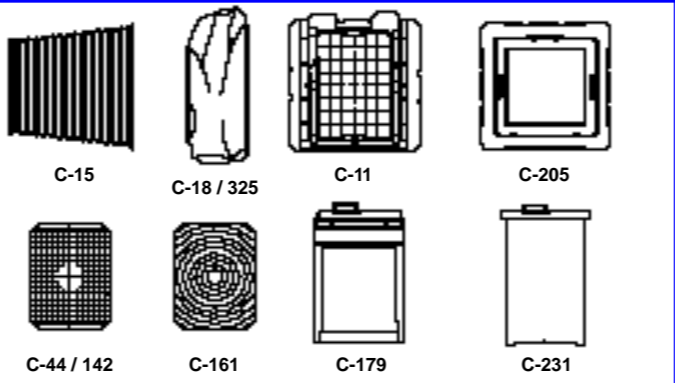

13x18cm/5x7" ACCESSORIES

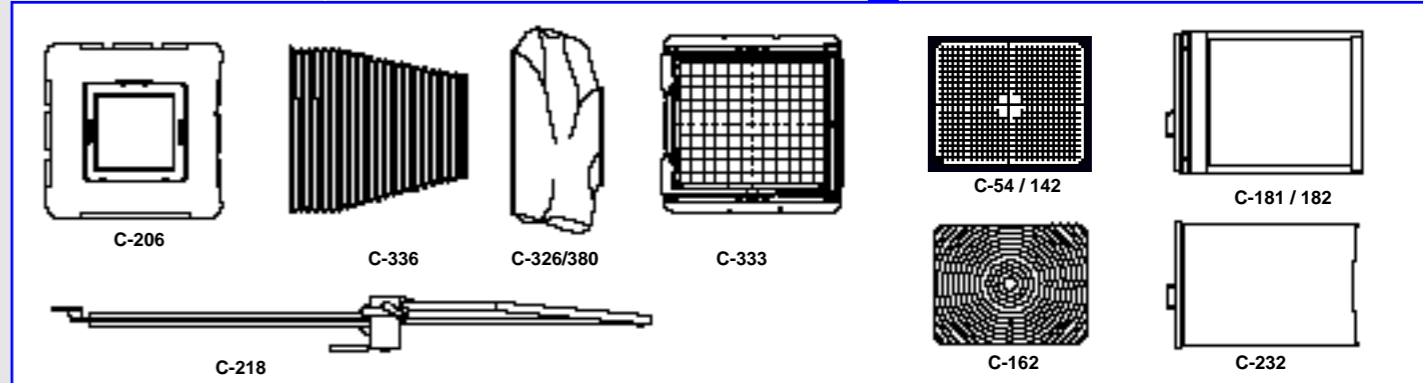

8x10" ACCESSORIES

DIGITAL ACCESSORIES

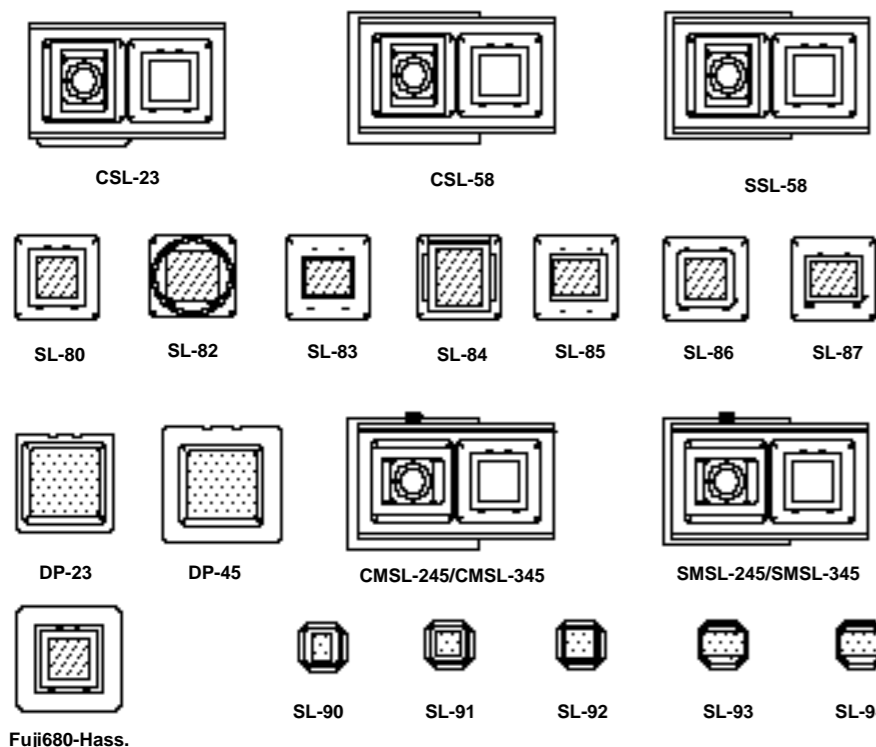

GENERAL ACCESSORIES

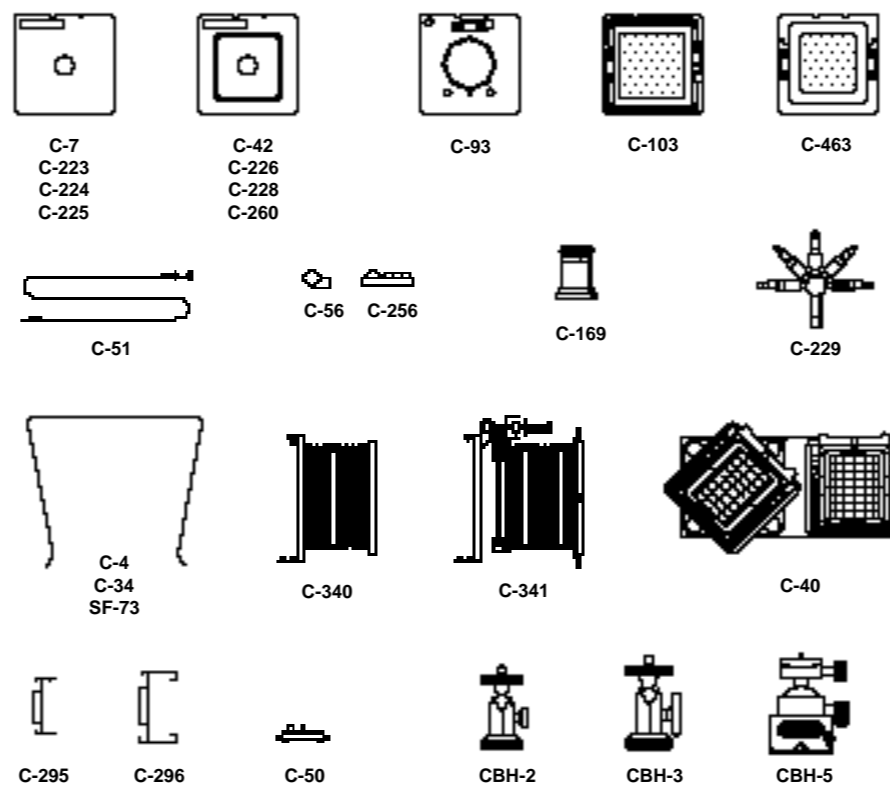

CAMBO

ACCESSORIES

SC Series
SF Series
Legend Series
Ultima Series

LENSES

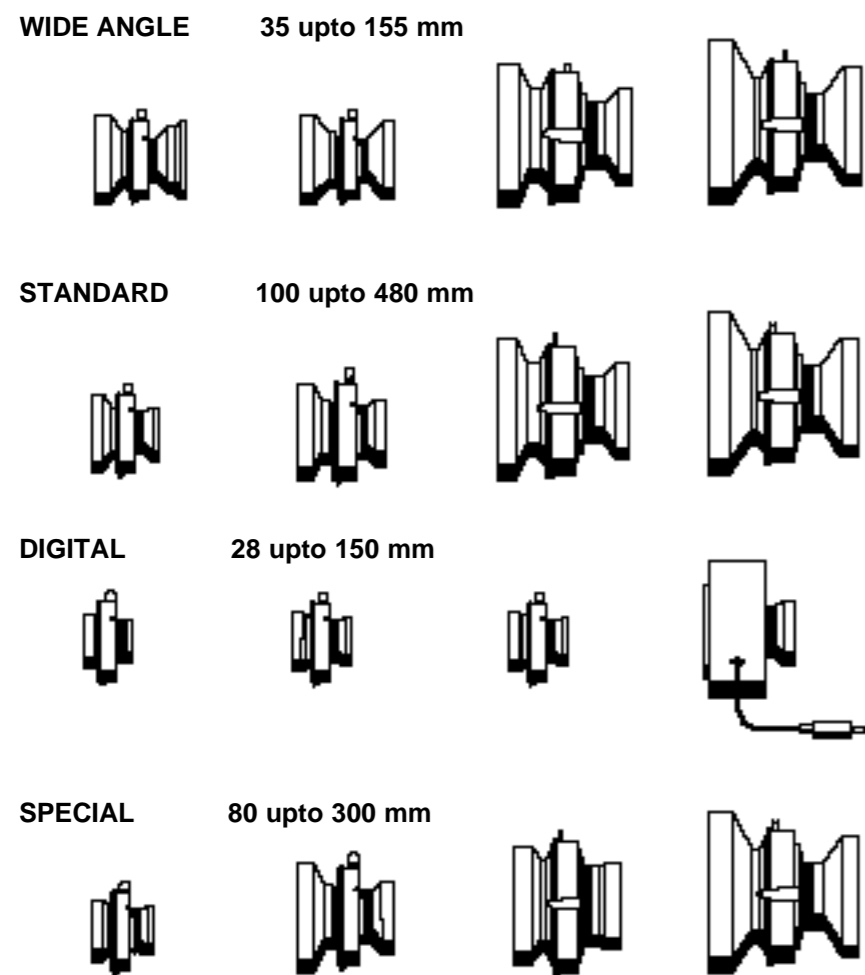

CASES

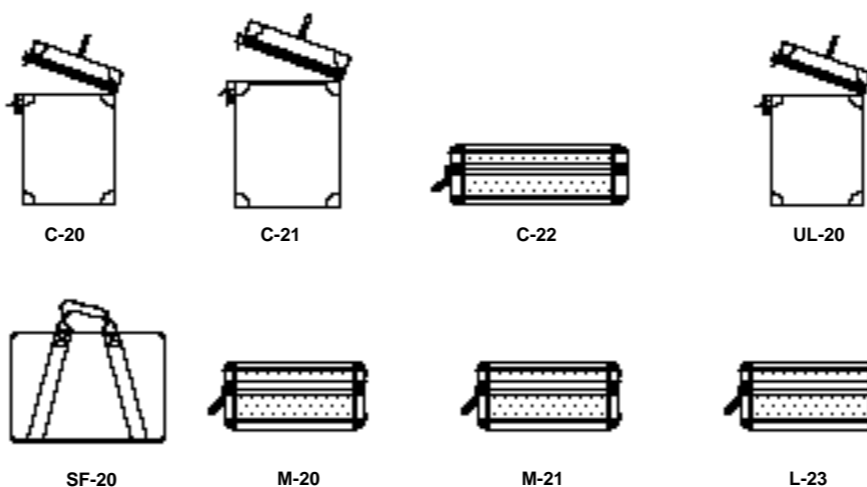

Your Cambo Distributor: